

HEAVY-DUTY PERFORMANCE TIPPER

TATA PRIMA 2528.K



10 CuM Tipper



6cyl Common Rail,
270HP Cummins Engine



ZF 9S
Transmission



World-class
Prima AC Cabin



Bogie
Suspension



5yr/10,000 hours
Driveline Warranty

TATA PRIMA 2528.K

ENGINE	
Model	Cummins ISBe 270 Euro-III
Capacity	6.7 L, 6 Cylinder
Type	Turbocharged Intercooler
Power (kW at r/min)	201 @ 2500
Torque (Nm at r/min)	975 @ 1,500
TRANSMISSION	
Model	ZF 9S1110 TD
Type	Synchromesh
Shift	Manual
No. of gears	9+1
First gear ratio	12.73 (Crawler)
Top gear ratio	1
DRIVE AXLE	
Reduction type	Single Reduction
Final ratio	6.42
CLUTCH	
Type	Single
Diameter (mm)	430
BRAKES	
Type	Full air Dual Circuit with ABS
Anti-lock braking system (ABS)	Standard
SUSPENSION	
Front	Parabolic Spring
Rear Overhang	Bogie

MAJOR DIMENSIONS	
Overall Height (mm)	3,486 (3,085)
Overall Length (mm)	8,337 (7,900)
Overall Width (mm)	2,590 (2,578)
Front Overhang (mm)	1,482
Rear Overhang (mm)	1,610 (1,173)
Wheelbase (mm)	4,570
Gradeability	63.7% (Crawler gear), 40% (1st Gear)
Tipper Box Size (cum)	10
MASS	
GVM (Kg)	25,500
Tare - total (T) (kg)	8,500
Permissible Rear axle weight (kg)	18,000
Permissible Front axle weight (kg)	7,500
Manufacturers Rear axle weight (kg)	18,000
Manufacturers Front axle weight (kg)	7,500
ELECTRICAL & FUEL	
Fuel Tank Capacity (Litre)	365
TYRES	
Tyres	315/80R22.5

Available in following applications:

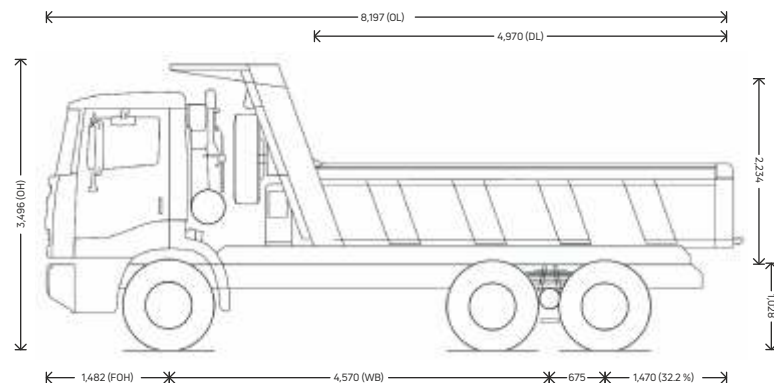

*Image is only for representation purposes.



For more information, please contact: **TATA AFRICA HOLDINGS (SA) (PTY) LTD.**

17 North Reef Road, Activia Park, Germiston, 1429, South Africa P.O. Box 901, Isando, 1600, Contact: Phone: + 27112559600, Website: <https://www.tata.co.za/>